

AMENDMENTS	DRN	REV	DATE	ISSUE
A	ORIGINAL	418/98		
B	DATE	9/6/93		
C	DATE	31/8/94		
D	DATE	14/8/95		
E	DATE	4/8/98		
F	DATE	28/7/00		
G	DATE	28/7/00		
H	DATE	28/7/00		

- NOTES:**
1. RECOMMENDED ASSEMBLY TORQUE OF HOLD DOWN NUTS - 310Nm
 2. IF TRENCHES ARE TO BE SHARED WITH OTHER UTILITIES, TRENCH DETAILS SHOULD BE IN ACCORDANCE WITH THE RELEVANT SHARED TRENCH AGREEMENT RATHER THAN AS SHOWN ON THIS DRAWING.

TOP OF RAGBOLT TO BE APPROXIMATELY
50mm ABOVE GROUND LEVEL

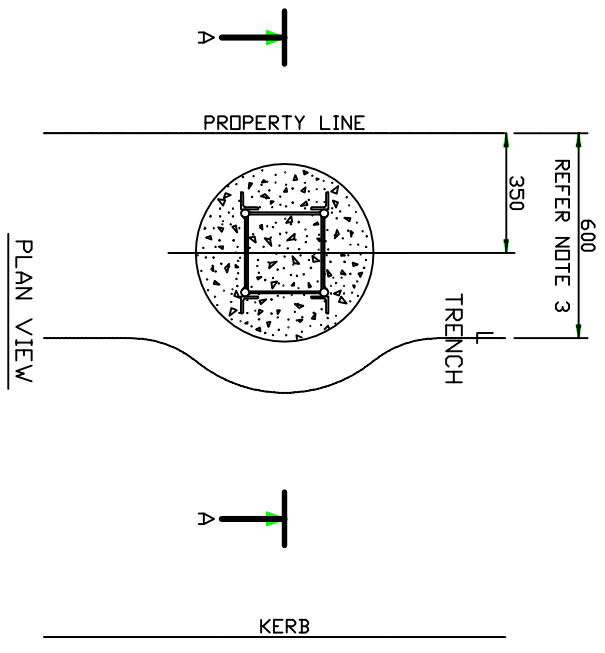
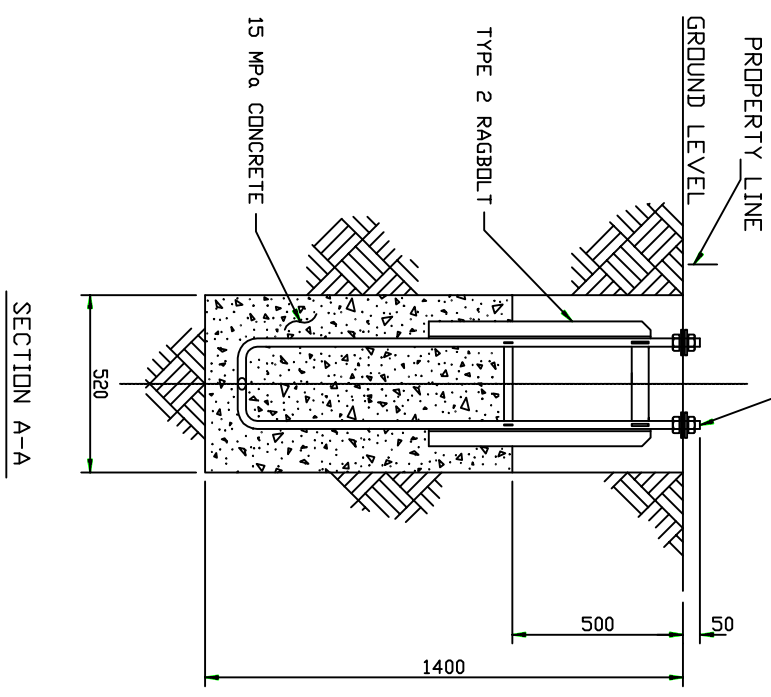

TYPE 2 RAGBOLT ASSEMBLY STOCK REF No. SR13771

	TYPE 2 RAGBOLT FABRICATION	REFERENCE DRAWINGS	015021
TYPE 2 FOUNDATION INSTALLATION DETAIL	DID NOT SCALE	AUTHORISED	W. ISLEY
	DIMENSIONS IN MILLIMETRES	NUMBER APPROVED ENGINEERING	075008
		SCALE	H
		SHEET No. 1 OF 1 SHEETS	8